

PROFILE

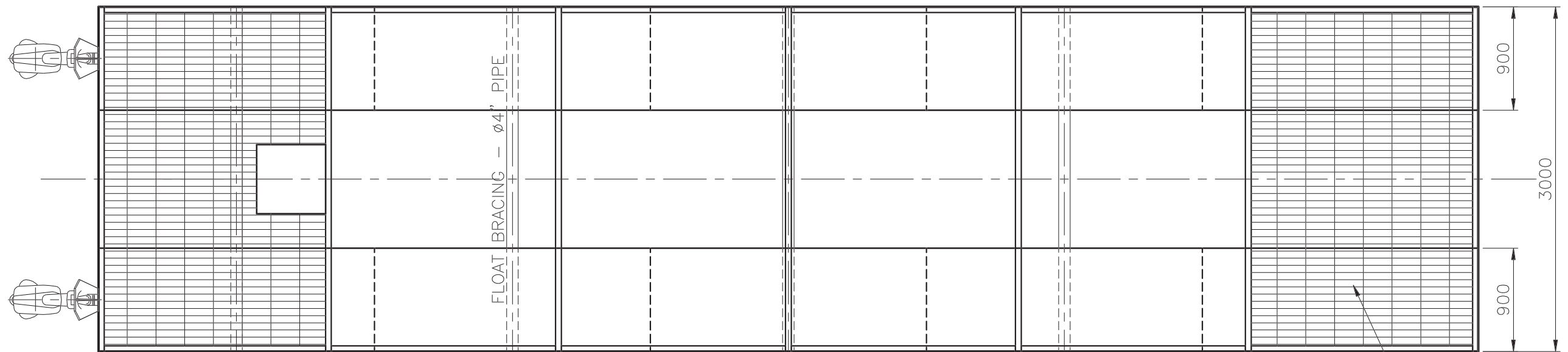

PLAN ON MAIN DECK

GALVANISED GRATING
OR WOODEN PLANK
DECKING (FULL DECK)

- FLOAT TUBES – 6MM PLATE
- BULKHEAD – 6MM PLATE
- FRAMES – 4x2 RHS
- FLOAT BRACING – Ø4" PIPE
- POWER – 2 x 60 HP OUTBOARD ENGINES
- TOTAL DECK AREA – 36 SQ. METRES
- TOTAL DEADWEIGHT – 5 TONNES

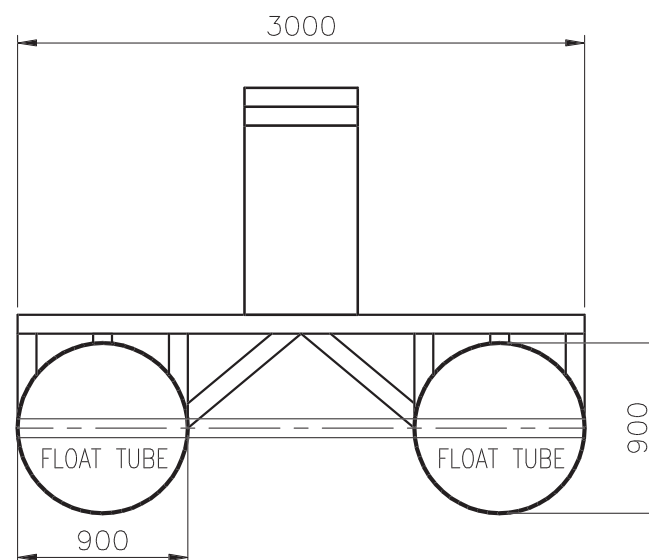

SECTION VIEW

PRINCIPAL PARTICULARS

LENGTH O.A. 12.00M
BREADTH MLD. 3.00M
DEPTH MLD. 0.90M

Designer :			Maast maritime	
Project :			PAKKA MOTORISED CAMATARAN BARGE	
Title: GENERAL ARRANGEMENT				
Date:	Drawn:	Checked:		
8/8/03	SDS	KELVIN		
Dwg. No.:	Scale:	Rev.		
PP4503 – D1 (SHT 1 OF 1)	1 : 40 (A3)	2		